

OWNER'S MANUAL

Color Video Camera

Please read this manual carefully before operating your set and retain it for future reference.



MODEL
L6323-Series
L6323-BP
L6323-BN

P/NO : MFL63745131(A)

Important Safety Instructions

1. Read these instructions.
 2. Keep these instructions.
 3. Heed all warnings.
 4. Follow all instructions.
 5. Do not use this apparatus near water.
 6. Clean only with dry cloth.
 7. Do not block any ventilation openings. Install in accordance with the manufacturer's instructions.
 8. Do not install near any heat sources such as radiators, heat registers, stoves, or other apparatus (including amplifiers) that produce heat.
 9. Do not defeat the safety purpose of the polarized or grounding-type plug. A polarized plug has two blades with one wider than the other. A grounding type plug has two blades and a third grounding prong. The wide blade or the third prong are provided for your safety. If the provided plug does not fit into your outlet, consult an electrician for replacement of the obsolete outlet.
 10. Protect the power cord from being walked on or pinched particularly at plugs, convenience receptacles, and the point where they exit from the apparatus.
 11. Only use attachments/accessories specified by the manufacturer.
 12. Use only with the cart, stand, tripod, bracket, or table specified by the manufacturer, or sold with the apparatus. When a cart is used, use caution when moving the cart/apparatus combination to avoid injury from tip-over.
- 
13. Unplug this apparatus during lightning storms or when unused for long periods of time.
 14. Refer all servicing to qualified service personnel. Servicing is required when the apparatus has been damaged in any way, such as power-supply cord or plug is damaged, liquid has been spilled or objects have fallen into the apparatus, the apparatus has been exposed to rain or moisture, does not operate normally, or has been dropped.

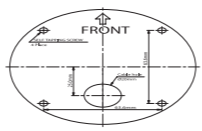
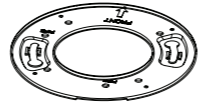
Accessories



Installation sticker	
Camera mounting bracket	
Wrench	
M4 Fixing screws	



CAUTION
RISK OF ELECTRIC SHOCK
DO NOT OPEN



CAUTION: TO REDUCE THE RISK OF ELECTRIC SHOCK
DO NOT REMOVE COVER (OR BACK)
NO USER-SERVICEABLE PARTS INSIDE
REFER SERVICING TO QUALIFIED SERVICE PERSONNEL.

-  This lightning flash with arrowhead symbol within an equilateral triangle is intended to alert the user to the presence of uninsulated dangerous voltage within the product's enclosure that may be of sufficient magnitude to constitute a risk of electric shock to persons.
-  The exclamation point within an equilateral triangle is intended to alert the user to the presence of important operating and maintenance (servicing) instructions in the literature accompanying the product.

FCC WARNING: This equipment may generate or use radio frequency energy. Changes or modifications to this equipment may cause harmful interference unless the modifications are expressly approved in the instruction manual. The user could lose the authority to operate this equipment if an unauthorized change or modification is made.

REGULATORY INFORMATION: FCC Part 15

This equipment has been tested and found to comply with the limits for a Class A digital device, pursuant to Part 15 of the FCC Rules. These limits are designed to provide reasonable protection against harmful interference when the equipment is operated in a commercial environment. This equipment generates, uses, and can radiate radio frequency energy and, if not installed and used in accordance with the instruction manual, may cause harmful interference to radio communications. Operation of this equipment in a residential area is likely to cause harmful interference in which case the user will be required to correct the interference at his own expense.

- A suitable conduit entries, knock-outs or glands shall be provided in the cable entries of this product in the end user.

- Caution: Danger of explosion if battery is incorrectly replaced. Replaced only with the same or equivalent type recommended by the manufacturer. Dispose of used batteries according to the manufacturer's instructions.
- Holes in metal, through which insulated wires pass, shall have smooth well rounded surfaces or shall be provided with brushings.

This Class A digital apparatus complies with Canadian ICES-003.
Cet appareil numérique de la classe A est conforme à la norme NMB-003 du Canada.

Warning: Do not install this equipment in a confined space such as a bookcase or similar unit.

Warning: Wiring methods shall be in accordance with the National Electric Code, ANSI/NFPA 70.

Warning: This is a class A product. In a domestic environment this product may cause radio interference in which case the user may be required to take adequate measures.

Warning: To reduce a risk of fire or electric shock, do not expose this product to rain or moisture.

Caution: This installation should be made by a qualified service person and should conform to all local codes.

Caution: To avoid electrical shock, do not open the cabinet. Refer servicing to qualified personnel only.

Caution: The apparatus shall not be exposed to water (dripping or splashing) and no objects filled with liquids, such as vases, shall be placed on the apparatus.

To disconnect power from mains, pull out the mains cord plug. When installing the product, ensure that the plug is easily accessible.

Specification

Item	L6323-BP	L6323-BN
Signal System	PAL	NTSC
Total/Effective Pixels	1028 X 596 / 976 X 582	1028 X 508 / 976 X 494
Image Device	6 mm CCD	
DSP	XDI-II	
Lens	2.8 mm to 10 mm Vari-focal lens	
Digital Zoom	X10	
Sync. System	Internal / Line Lock	
Scanning Frequency (H/V)	15.625 kHz / 50 Hz	15.734 kHz / 59.94 Hz
Horizontal Resolution	650 TV Lines	
S/N Ratio	50 dB	
Minimum Illumination (30 IRE)	Color mode	0.0003 lx (Sens-up Auto, F1.2)
	B/W mode	0.000 03 lx (Sens-up Auto, F1.2)
Control Method	Key Button / RS-485	
Video Output Signal	1 Vp-p Composite (75 Ω)	
Day & Night	DAY / NIGHT / AUTO	
BACKLIGHT	OFF / WDR(ACE) / BLC / HSBLCL	
3D-DNR	OFF / LOW / MIDDLE / HIGH	
Auto Gain Control	OFF / LOW / MIDDLE / HIGH	
Electronic Shutter Speed	1/50 to 1/120 000	1/60 to 1/120 000

CE LG Electronics hereby declares that this/these product(s) is/are in compliance with the essential requirements and other relevant provisions of Directive 2004/108/EC, 2006/95/EC, and 2009/125/EC.
European representative :
LG Electronics Service Europe B.V.
Veluwezoom 15, 1327 AE Almere,
The Netherlands (Tel : +31-(0)36-547-8888)

Disposal of your old appliance

1. When this crossed-out wheeled bin symbol is attached to a product it means the product is covered by the European Directive 2002/96/EC.
2. All electrical and electronic products should be disposed of separately from the municipal waste stream via designated collection facilities appointed by the government or the local authorities.
3. The correct disposal of your old appliance will help prevent potential negative consequences for the environment and human health.
4. For more detailed information about disposal of your old appliance, please contact your city office, waste disposal service or the shop where you purchased the product.

EEE Compliance with Directive. (for Turkey only)



Item	L6323-BP	L6323-BN
Sens-Up	OFF / AUTO	
White Balance	ATW / AUTO / AWC \blacklozenge PUSH / MANUAL	
Motion Detection	REGIONAL MD / SMART MD / TAMPERING MD	
Privacy Zone Masking	RECTANGLE	8 AREAS
	CIRCLE	2 AREAS
	POLYGON	2 AREAS
Stabilizer(EIS)	On / Off	
User Color Mode	NATURAL / COOL / WARM / VIVID	
Power Source	DC 12V / AC 24V	
Power Consumption	2.8 W	
Operation Temp.	-10 °C to 50 °C	
Storage Temp.	-20 °C to 60 °C	
Operation Humidity	0 % RH to 80 % RH	
Storage Humidity	0 % RH to 85 % RH	
Weight	840 g	
Dimension (Ø x H)	165 mm x 100.3 mm	

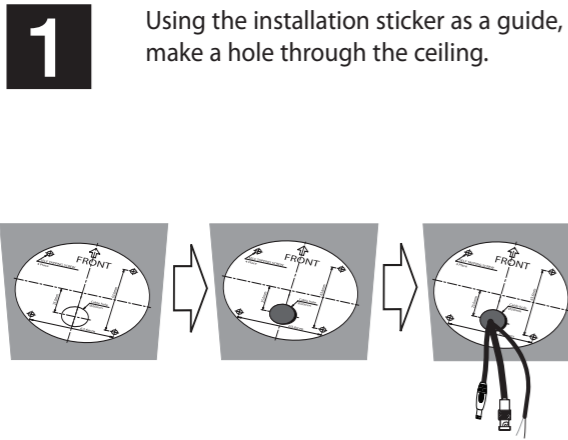

- <FRANÇAIS> En vous servant de la vignette d'installation comme guide, percez un trou dans le plafond.
- <ITALIANO> Utilizzando l'adesivo di installazione come guida, fare un foro nel soffitto.
- <ČEŠTINA> S použitím instalační nálepky jako šablony vyvrtejte otvor do stropu.
- <POLSKI> Używając szablonu instalacyjnego wykonać otwór w suficie.
- <ESPAÑOL> Use la pegatina de instalación como guía, haga un agujero en el techo.
- <NEDERLANDS> Gebruik de installatiesticker als patroon om een gat door het plafond te boren.
- <PORTUGUÊS> Usando a etiqueta de instalação como guia, faça um furo através do teto.

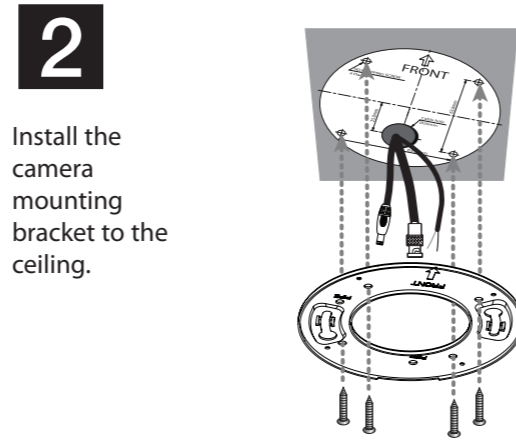

- <FRANÇAIS> Fixez le support de montage de la caméra au plafond.
- <ITALIANO> Installare la staffa per il montaggio della videocamera al soffitto.
- <ČEŠTINA> Instalujte mechanizmus pro uchycení kamery na strop.
- <POLSKI> Zainstalować na suficie wspornik montażowy kamery.
- <ESPAÑOL> Instale el soporte de montaje de la cámara en el techo.
- <NEDERLANDS> Monteer de camerabeugel aan het plafond.
- <PORTUGUÊS> Instale o suporte de montagem no teto.

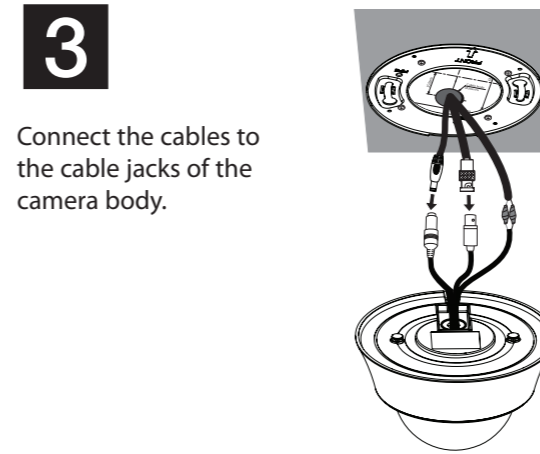

- <FRANÇAIS> Raccordez les câbles aux prises correspondantes du corps de la caméra.
- <ITALIANO> Collegare i cavi alle prese sul corpo della videocamera.
- <ČEŠTINA> Zapojte kabely do konektorů těla kamery.
- <POLSKI> Podłączyć kable do gniazd znajdujących się w obudowie kamery.
- <ESPAÑOL> Conecte los cables a los conectores de cable del cuerpo de la cámara.
- <NEDERLANDS> Bevestig de kabels in de kabelingangen van het camerahuis.
- <PORTUGUÊS> Conecte os cabos nas entradas de cabos no corpo da câmera.

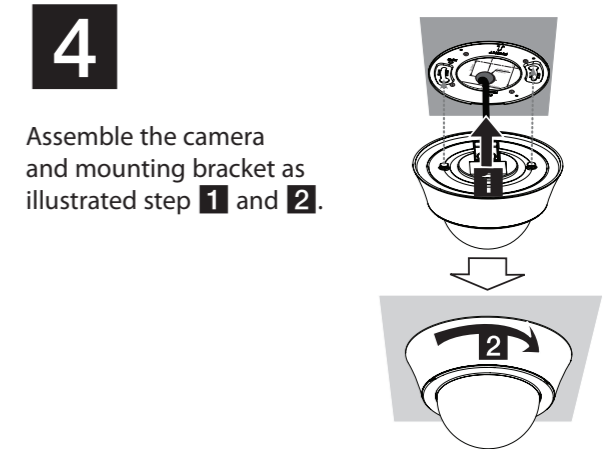

- <FRANÇAIS> Assemblez la caméra et le support de montage comme illustré aux étapes 1 et 2.
- <ITALIANO> Montare la videocamera e la staffa come illustrato nei passi 1 e 2.
- <ČEŠTINA> Připevněte kameru a mechanismus pro uchycení jak je vyobrazeno v kroku 1 a 2.
- <POLSKI> Zamontować kamerę na wsporniku montażowym tak, jak to pokazano na ilustracji kroku 1 oraz 2.
- <ESPAÑOL> Monte la cámara y monte el soporte según se ilustra en el paso 1 y 2.
- <NEDERLANDS> Bevestig de camera aan de montagebeugel zoals in stap 1 en stap 2 aangegeven.
- <PORTUGUÊS> Montar a câmera e o suporte de montagem conforme os passos na ilustração 1 e 2.

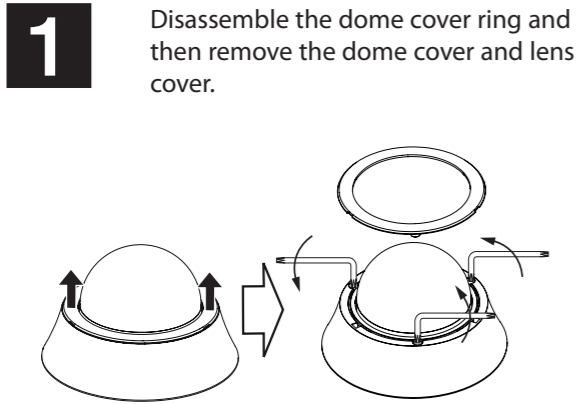

- <FRANÇAIS> Démontez la bague du capot de dôme, puis retirez le capot de dôme et le cache de la lentille.
- <ITALIANO> Smontare l'anello di copertura della cupola e poi rimuovere la copertura della cupola e la copertura della lente.
- <ČEŠTINA> Demontujte kroužek kopulového krytu, poté odstraňte kopulový kryt a kryt objektivu.
- <POLSKI> Zdemontować pierścień pokrywy kopuły, a następnie pokrywę kopuły oraz obiektyw.
- <ESPAÑOL> Desmonte el anillo de la tapa del domo y a continuación retire la tapa del domo y la tapa de las lentes.
- <NEDERLANDS> Demonteer de afdekking van de bol en verwijder de bolafsluiting en lensafsluiting.
- <PORTUGUÊS> Desmontar o anel da tampa do domo e remover a tampa do domo e das lentes.

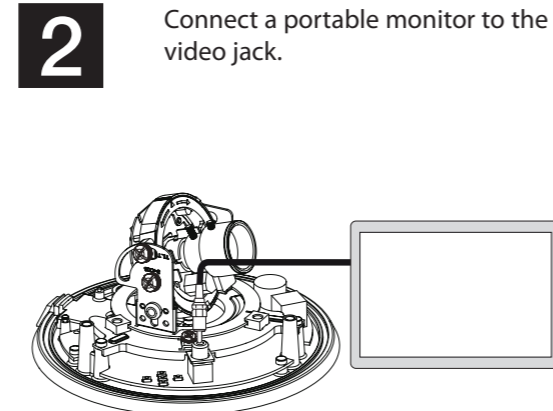

- <FRANÇAIS> Raccordez un moniteur portable à la prise vidéo.
- <ITALIANO> Collegare un monitor portatile alla presa video.
- <ČEŠTINA> Zapojte přenosný monitor ke konektoru videa.
- <POLSKI> Podłączyć monitor przenośny do złącza video (video jack).
- <ESPAÑOL> Conecte un monitor portátil al conector de video.
- <NEDERLANDS> Sluit een draagbare monitor op de video-uitgang aan.
- <PORTUGUÊS> Conectar o monitor portátil na tomada de vídeo.

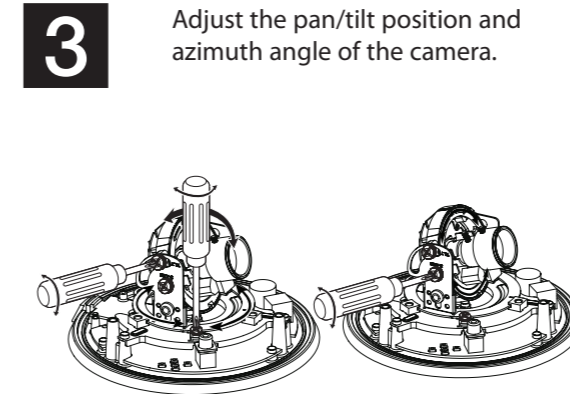

- <FRANÇAIS> Réglez l'assiette/inclinaison et l'angle d'azimut de la caméra.
- <ITALIANO> Regolare la posizione di inclinazione/ripresa e l'angolo azimutale della videocamera.
- <ČEŠTINA> Nastavte panoramatickou pozici/náklon kamery a úhel azimutu.
- <POLSKI> Ustaw panoramę/pochylenie oraz kąt obrotu kamery.
- <ESPAÑOL> Ajuste la posición panorámica/inclinación y el ángulo de azimut de la cámara.
- <NEDERLANDS> Pas de panorama/schuine positie en azimuthhoek van de camera aan.
- <PORTUGUÊS> Ajustar a posição de girar e inclinar e o ângulo azimut da câmera.

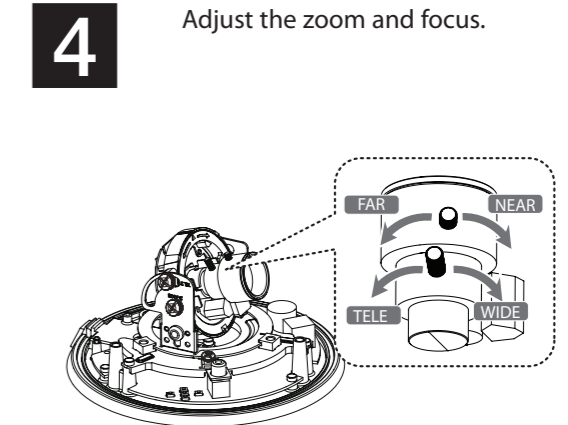

- <FRANÇAIS> Réglez le zoom et la mise au point.
- <ITALIANO> Regolare lo zoom e la messa a fuoco.
- <ČEŠTINA> Nastavte přiblížení/oddálení a zaostření.
- <POLSKI> Ustaw przybliżenie oraz ostrość.
- <ESPAÑOL> Ajuste el zoom y el enfoque.
- <NEDERLANDS> Stel de zoomstand en de scherpstelling van de camera in.
- <PORTUGUÊS> Ajustar o foco e o zoom.